

**Part Number: PU060-42S16-P1**

**Kit Contents**

Item #	Quantity Req'd.	Description
1	1	Front Passenger Side Mudguard
2	1	Front Driver Side Mudguard
3	1	Rear Passenger Side Mudguard
4	1	Rear Driver Side Mudguard
5	1	Hardware Kit
6	1	Instruction Sheet (Electronic Copy)

**Hardware Bag Contents**

Item #	Quantity Req'd.	Description
1	4	M5 x 20mm Screw
2	8	#14 x 19 mm Hex Head Screw
3	4	M5 Spring Clip
4	2	Push Pin

**Additional Items Required For Installation**

Item #	Quantity Req'd.	Description
1		
2		
3		

**Conflicts**

--

**Recommended Tools**

<b>Personal &amp; Vehicle Protection</b>	<b>Notes</b>
None	
<b>Special Tools</b>	<b>Notes</b>
None	
<b>Installation Tools</b>	<b>Notes</b>
Screwdriver	Phillips #2, #3
Socket Driver	8mm (5/16"), 10mm (3/8")
Extension	3"
Clean Cloth/Rag	
<b>Special Chemicals</b>	<b>Notes</b>
Cleaner	VDC approved

**General Applicability**

All models
------------

**Recommended Sequence of Application**







Item #	Accessory
1	Mudguards
2	Running Boards
3	

\*Mandatory

**Vehicle Service Parts** (may be required for reassembly)

Item #	Quantity Req'd.	Description
1		
2		
3		

**Legend**

	<b>STOP:</b> Damage to the vehicle may occur. Do not proceed until process has been complied with.
	<b>OPERATOR SAFETY:</b> Use caution to avoid risk of injury.
	<b>CAUTION:</b> A process that must be carefully observed in order to reduce the risk of damage to the accessory/vehicle and to ensure a quality installation.
	<b>TOOLS &amp; EQUIPMENT:</b> Used in Figures calls out the specific tools and equipment recommended for this process.
	<b>REVISION MARK:</b> This mark highlights a change in installation with respect to previous issue.
	<b>SAFETY TORQUE:</b> This mark indicates that torque is related to safety.

Care must be taken when installing this accessory to ensure damage does not occur to the vehicle. The installation of this accessory should follow approved guidelines to ensure a quality installation.

These guidelines can be found in the "Accessory Installation Practices" document.

This document covers such items as:-

- Vehicle Protection (use of covers and blankets, cleaning chemicals, etc.).
- Safety (eye protection, rechecking torque procedure, etc.).
- Vehicle Disassembly/Reassembly (panel removal, part storage, etc.).
- Electrical Component Disassembly/Reassembly (battery disconnection, connector removal, etc.).

Please see your Toyota dealer for a copy of this document.

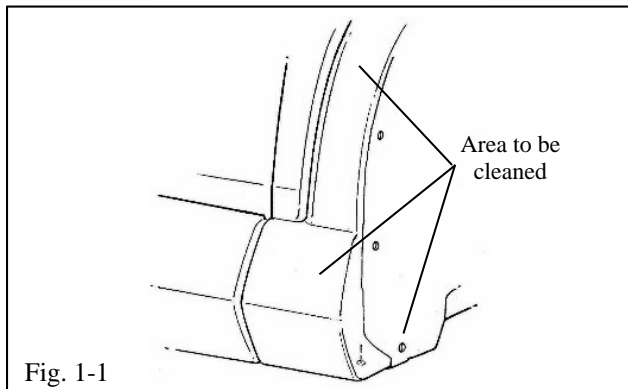

### 1. Clean the Front Mounting Area.

-  (a) Clean and degrease the front body panel where the mudguard is to be located with a clean cloth and soap/water mixture (Fig. 1-1).

### 2. Install the Front Mudguard.

- (a) While holding the part up and into body panel, mount the mudguard on the body panel and install the supplied #14 screw (hex head) in locations B, then tighten (Fig. 2-1). Do not overtighten the screws.
- (b) Hold the part up and into body panel and install a supplied #14 screw (hex head) in location A, then tighten (Fig. 2-1). Do not overtighten the screws.
- (c) Hold the part up and into body panel and install a supplied #14 screw (hex head) in location C, then tighten (Fig. 2-1). Do not overtighten the screws.

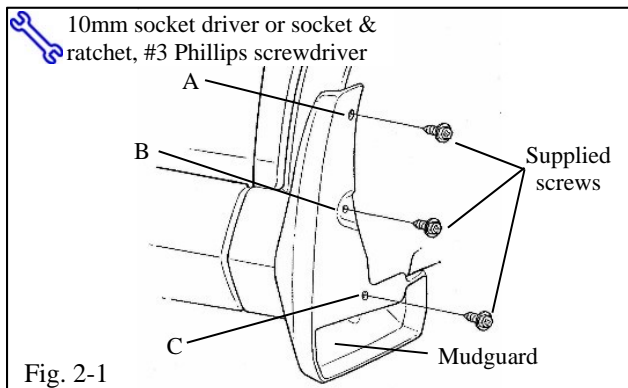

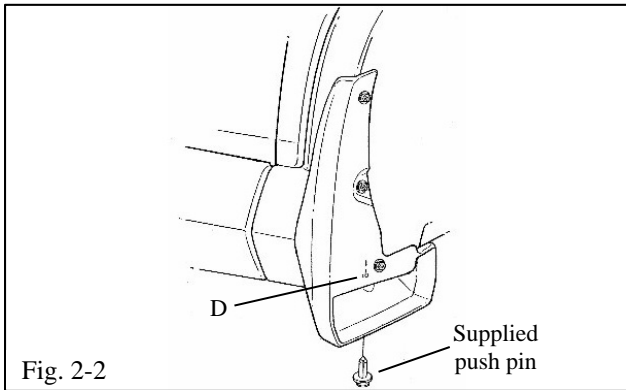

- (d) Hold the part into the body panel and install a supplied push pin in location D (Fig. 2-2).
- (e) Repeat Steps 1 and 2 on the other side.

**3. Clean the Rear Mounting Area.**

-  (a) Clean and degrease the rear bumper panel where the mudguard is to be located with a clean cloth and soap/water mixture.

**4. Remove and Install the Rear Hardware.**

- (a) Remove and **RETAIN** the existing screw at locations B and D (Fig. 4-1).

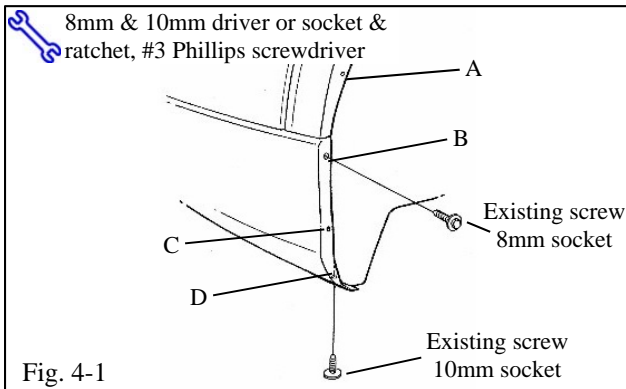

-  (b) Install supplied spring clips over the panel edge dimple at locations A and C with the turned up edge on the inside of the panel (Fig. 4-2).

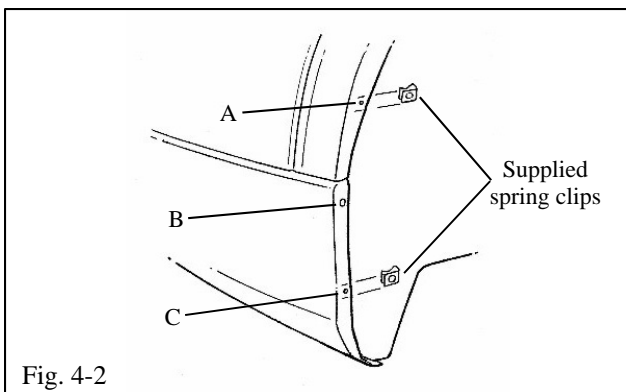

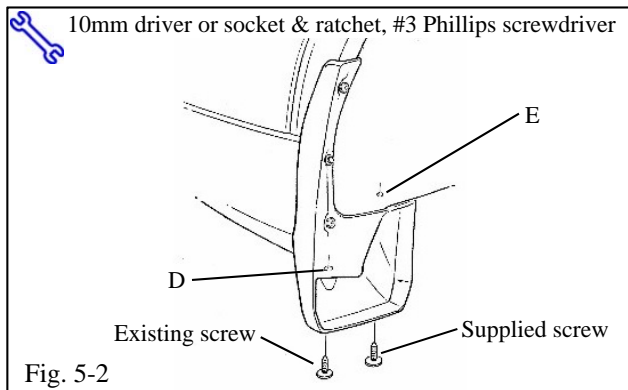
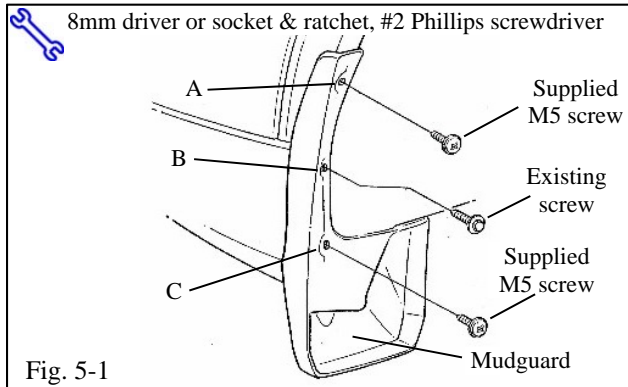

**5. Install the Rear Mudguard.**

- (a) Hold the part up and into the bumper panel and reinstall the existing screw in location B, then tighten (Fig. 5-1).
- (b) Hold the part up and into the bumper panel and install supplied M5 screws in the dimple and spring clips at location A then C, and then tighten (Fig. 5-1).
- (c) Hold the mudguard up and into the bumper panel and install a supplied #14 (hex head) screw in location E, then tighten (Fig. 5-2). Do not overtighten the screw.
- (d) Hold the part up and into the bumper panel and reinstall the existing screw in location D, then tighten. Do not overtighten the screw (Fig. 5-2).
- (e) Repeat Steps 3-5 on the other side.

Checklist - these points **MUST** be checked to ensure a quality installation.

<u>Check:</u>	<u>Look For:</u>
<p><u>Accessory Function Checks</u></p> <ul style="list-style-type: none"><li><input type="checkbox"/> Gaps between mudguards and body side</li><li><input type="checkbox"/></li><li><input type="checkbox"/></li><li><input type="checkbox"/></li></ul>	<p>Gaps greater than 1.0 mm</p>
<p><u>Vehicle Function Checks</u></p> <ul style="list-style-type: none"><li><input type="checkbox"/></li><li><input type="checkbox"/></li><li><input type="checkbox"/></li></ul>	
<p><u>Vehicle Appearance Check</u></p> <ul style="list-style-type: none"><li><input type="checkbox"/> After accessory installation and removal of protective cover(s), perform a visual inspection.</li></ul>	<p>Ensure no damage (including scuffs and scratches) was caused during the installation process. (For PPO installations, refer to TMS Accessory Quality Shipping Standard.)</p>